

TXR-800

TITAN™

ROTARY PHASE CONVERTER DATA SHEET

“TITAN™ is your solution”

When you have demanding three phase power requirements and when need a phase conversion system that is up to the challenge you need the TITAN™. Whether you're powering a single Machine or an entire facility, TITAN™ has you covered.

The TITAN™ line of phase conversion systems are engineered to provide stable single to three phase power. TITAN™ phase conversion systems use rotary power generation that provides the benefit of high surge capacity free of the noise and wave form distortion associated with some other phase conversion technologies.



The possibilities are endless with TITAN!™ With its versatility it can power any three phase machinery, ranging from Miller® welders and Trane® HVAC systems, to oil drilling platform equipment or even entire production facilities. TEMCo is on the forefront of phase converter technology and continues to innovate and provide products that produce superior quality power.

Common Phase Converter Applications:

- | | | |
|--------------------|----------------------------|-------------|
| ▪ Machine Shops | ▪ Petrochemical processing | ▪ High Tech |
| ▪ Woodworking | ▪ Ship Yards | ▪ Military |
| ▪ Farm Equipment | ▪ Oil Fields | ▪ Aerospace |
| ▪ Pumping Stations | ▪ Irrigation | ▪ Hospitals |

“Make Your Money Work for You”

The TEMCo TITAN™ Phase Conversion line has been engineered to dramatically reduce the cost of long term maintenance.

Of course none of this means anything without a guarantee... **It comes with a 10 Year Warranty – “Now that’s Quality”**



Multi-staged to reduce inrush.

TEMCo TITAN™ series Phase Converters utilize a multi-staged generator starting arrangement to keep startup inrush to a minimum. This soft start technology dramatically reduces stress on utility feed equipment and prevents incoming line voltage sag normally associated with starting large industrial equipment.

Many utilities impose maximum inrush current restrictions for their customers. TITAN is designed to work within these limits while still providing quality, high capacity three phase power.

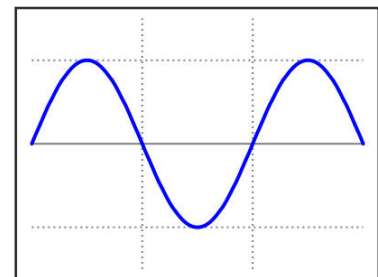

rev 1.0

Corporate Headquarters: TEMCo – Tower Electric Motor Company 41474 Christy St. Fremont CA 94538 USA
Inside USA (800) 613-2290 International (510) 490-2187 Fax (510) 490-1507 www.temcoindustrialpower.com

TXR-800

TITAN™

ROTARY PHASE CONVERTER DATA SHEET

TITAN™ Features



100% Copper Windings
(Energy Efficient,
Environmentally Friendly)

**HEAVY
DUTY**

Rugged Heavy Duty
multi-stage Rotary Design



Quiet Operation, 63db @
10ft
(No Louder Than Normal
Conversation)



American Design &
Assembly

10

Industry Leading 10 Year
Warranty



100% Satisfaction
Guarantee*



TEMCo DLC- Computerized Control and monitoring System.

A multitude of sensors monitor everything from incoming line voltage to generator temperature and current output. Using this data the DLC unit can control the operation of the converter, and shut down power if necessary to protect itself and your equipment. System faults are easily identified via the LCD control panel making diagnostics simple and quick.



Designed for CNC First - Not as an Afterthought.

TEMCo was one of the first to provide a single to three phase power conversion solution for CNC Equipment users. In fact, TEMCo is the only company to offer a 100% Satisfaction Guarantee* backing the TITAN™ Phase Converter Line for the operation of ANY CNC machine!



Unique Design Approach to Connections

TEMCo uses the simplest and fastest connections systems in the phase converter industry. Save time during installation through clearly marked, committed connections points for your single phase input, three phase output and grounding connections. Just insert each wire and tighten it down; it's that simple.

* Ask your sales representative for details.

rev 1.0

Corporate Headquarters: TEMCo – Tower Electric Motor Company 41474 Christy St. Fremont CA 94538 USA
Inside USA (800) 613-2290 International (510) 490-2187 Fax (510) 490-1507 www.temcoindustrialpower.com

TXR-800

TITAN™

ROTARY PHASE CONVERTER DATA SHEET

Complete control, Right at your fingertips.

Titans' simple user interface and 3" LCD makes it easy to view the status of the converter, start or stop the unit, and diagnose any faults that may occur. Faults codes are displayed in plain English so there is no doubt about how to bring equipment back online. That means no cryptic error codes or confusing flashing lights when trying to diagnose a problem.



Customize to fit your needs.

TITAN is built to meet your power conversion demands. Each unit is built to meet the exact specifications of the customer, with a huge variety of options to choose from. From outdoor NEMA 3R rated enclosures, remote control terminals, networking options and even custom colors, TITAN offers you the customizability that you need to create a power conversion solution suited to your installation.



Quality from the ground up.

TEMCo utilizes only top quality components in the construction of all of our phase converters, and the TITAN is no exception. Every component is chosen to provide the time proven reliability that makes TEMCo the industry leader in power conversion technology.

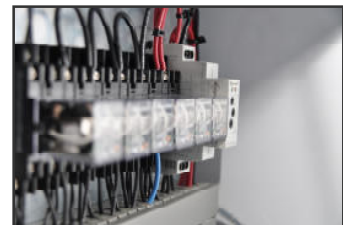

Superior weather resistance

TITAN comes standard with a NEMA 3R rated outdoor enclosure capable of withstanding some of the harshest weather conditions. From low laying wetlands to windswept mountaintops, wherever you need quality three phase power, TITAN is ready to deliver!



rev 1.0

Corporate Headquarters: TEMCo – Tower Electric Motor Company 41474 Christy St. Fremont CA 94538 USA
Inside USA (800) 613-2290 International (510) 490-2187 Fax (510) 490-1507 www.temcoindustrialpower.com

TXR-800

TITAN™

ROTARY PHASE CONVERTER DATA SHEET

TITAN™ Phase Converter Specifications

1-phase input voltage**	230v, 460V (max deviation ±10%)
1-phase input frequency	60Hz
3-phase output voltage	= Input voltage + 5% on T2 (non-loaded)
3-phase output frequency	60Hz
3-phase output voltage tolerance	± 5%
3-phase output phase angle	120°
Temperature rating	40° C Ambient
Ambient humidity	<95% (non-condensing)
Maximum altitude (de-rate .004% for each foot above 3300ft)	3300 ft above sea level
Enclosure	NEMA 3R
Recommended for All General Electrical Loads	YES
Recommended for All CNC and Electronic Loads	YES
Microprocessor Controlled Systems Management	YES

Input Voltage**		230V	460V
Output Configuration		DELTA	DELTA
CNC & ELECTRONIC LOADS			
Continuous kW output		420 kW	420 kW
Continuous 3-phase Amp output		1320 A	660 A
RESISTIVE ELECTRICAL LOADS			
Continuous kW output		788 kW	788 kW
Continuous 3-phase Amp output		1980 A	990 A
INDUCTIVE ELECTRICAL LOADS			
Continuous kW output		547 kW	547 kW
Continuous 3-phase Amp output		1716 A	858 A
MOTOR LOADS			
Maximum Easy run or start HP		800 HP	800 HP
Maximum Medium run or start HP		600 HP	600 HP
Maximum Hard run or start HP		400 HP	400 HP
Maximum group load HP		900 HP	900 HP
RLA 1-phase input	calculated based on three phase load x 1.732		
Approx. 1-phase idle amps		293 A	147 A
MCA 1-phase		2286 A	1143 A
Min 1-phase fuse		2300 A	1150 A
MOP 1-phase		3450 A	1700 A

RLA – Rated Load Amps

MCA – Minimum Circuit Amps

MOP – Maximum Overcurrent Protection

rev 1.0

Corporate Headquarters: TEMCo – Tower Electric Motor Company 41474 Christy St. Fremont CA 94538 USA
 Inside USA (800) 613-2290 International (510) 490-2187 Fax (510) 490-1507 www.temcoindustrialpower.com

TXR-800

TITAN™

ROTARY PHASE CONVERTER DATA SHEET

TITAN™ Phase Converter Dimensions*

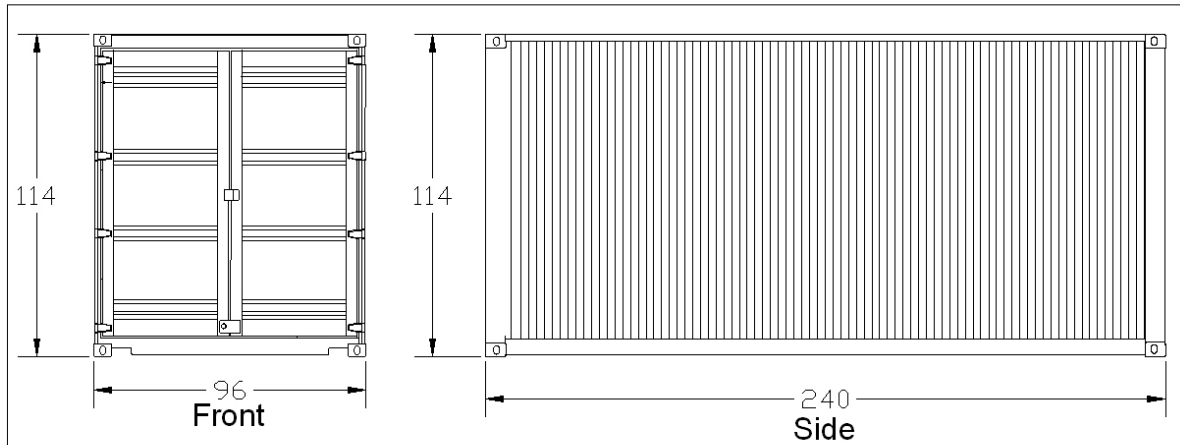

Approximate Weight: 14388 lbs.

Shipping Dimensions: 96"W x 114"H x 240"D

*Approximate dimensions, given in inches, subject to change without notice.

rev 1.0

Corporate Headquarters: TEMCo – Tower Electric Motor Company 41474 Christy St. Fremont CA 94538 USA
Inside USA (800) 613-2290 International (510) 490-2187 Fax (510) 490-1507 www.temcoindustrialpower.com

ROTARY PHASE CONVERTER DATA SHEET

Electrical Connection Diagram

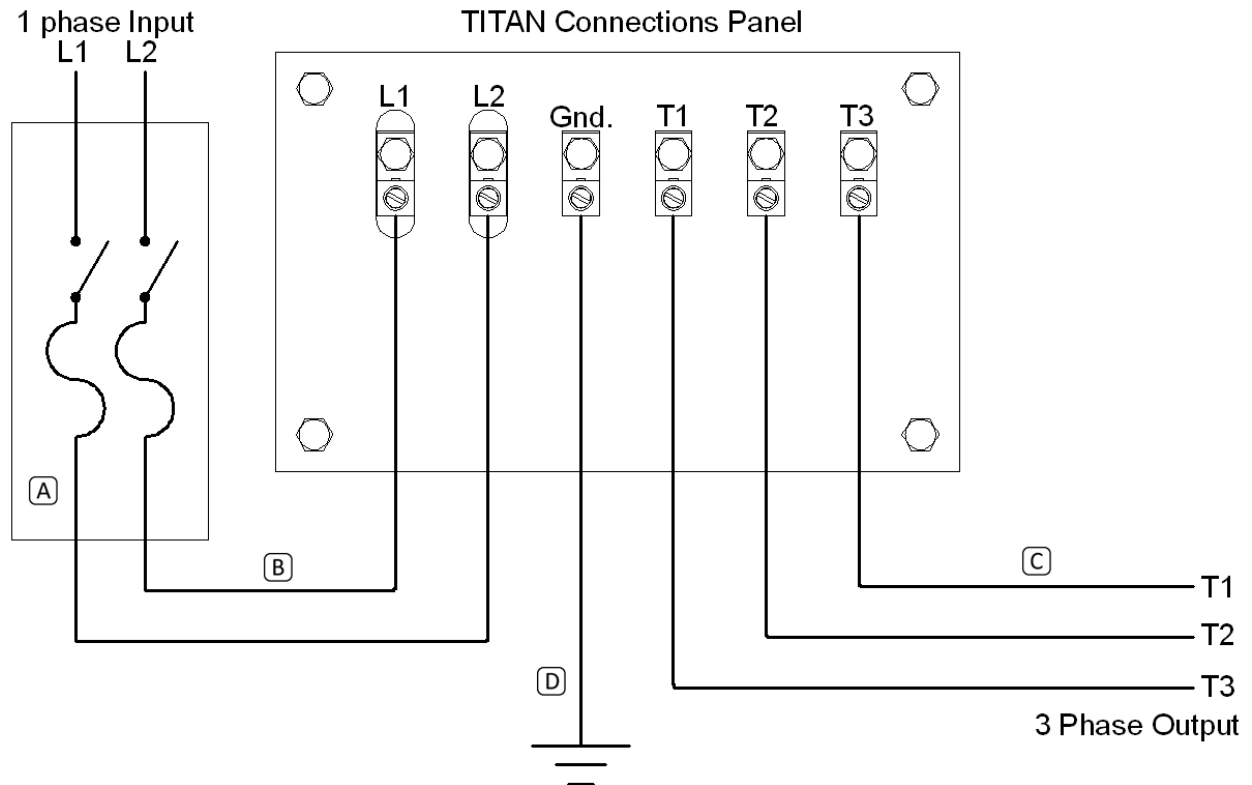

- A** Customer supplied Single Phase Fused Disconnect, or Circuit Breaker: Refer to technical specifications for sizing. For optimal protection, device setting(s) should be based on minimum requirements of three phase load converted to single phase ($3\text{-phase load amps} \times 1.732$) but not lower than recommendation in technical specifications.
- B** Single phase supply conductors should be based on circuit protection rating as required by NEC.
- C** Three phase output conductors should be based on circuit protection rating as required by NEC and the requirement of the three phase load equipment.
- D** Ensure that unit and all connected equipment are properly grounded according to NEC

rev 1.0

Corporate Headquarters: TEMCo – Tower Electric Motor Company 41474 Christy St. Fremont CA 94538 USA
Inside USA (800) 613-2290 International (510) 490-2187 Fax (510) 490-1507 www.temcoindustrialpower.com

Optional Remote Interface Terminal

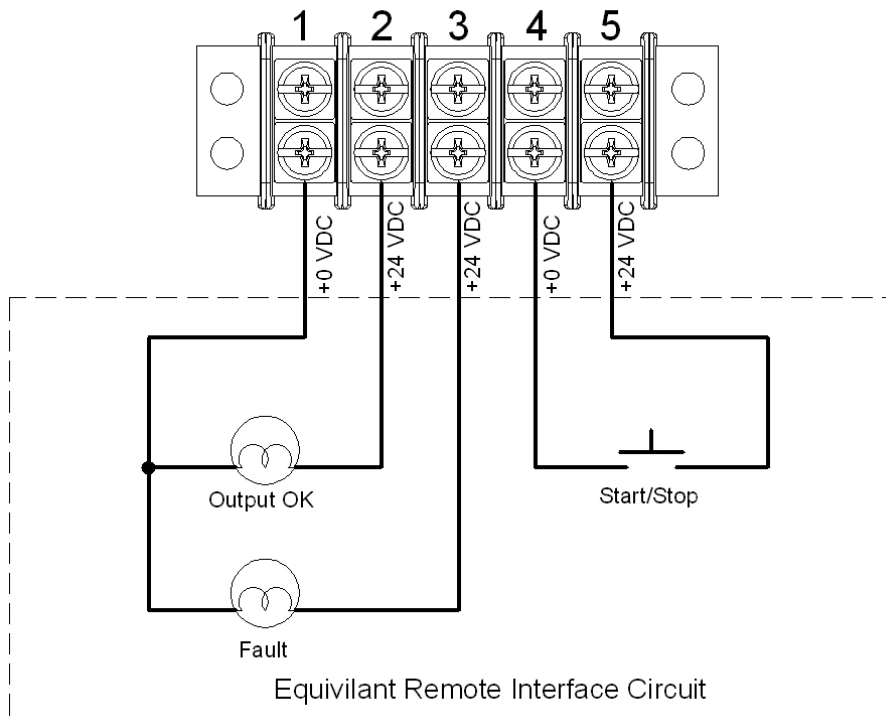

An optional analog interface is available and allows for remote system operation and monitoring via an operator panel or PLC control system.

TXR-800

TITAN™

ROTARY PHASE CONVERTER DATA SHEET

Installation Notes:

1. These diagrams are not intended to replace or supersede any requirements of local, state or national electrical codes.
2. Use only protective dual element time delay fuses or a magnetic circuit breaker that carry an amperage rating within the limits set by the technical specifications.
3. Before attempting first start up, verify that the single phase input of the TEMCo Phase Converter has been connected to protective dual element time delay fuses, or circuit breaker that carry an amperage rating within the limits set by the table in section 18.0 Overload Protection. Failure to connect the single phase input of the TEMCo Phase Converter to a specified overload protection device can cause permanent equipment damage and will void the TEMCo Phase Converter warranty.
4. No load voltage on the three phase output from T1 – T2 or T3 – T2 will exceed T1 – T3 by 5% (T2 on the output is the generated line). Voltages will balance when a load is applied.
5. Do not connect control circuits which require neutral to the generated line T2 on the three phase output. This TEMCo Phase Converter provides a three phase DELTA output. On the output, voltage from T2 (generated line) to ground /neutral will be 180-220V on a 208-240V system. If a WYE (or 4 wire) three phase output is required, a three phase DELTA to WYE transformer is required. Please consult your sales representative for the supply of this type of transformer.

rev 1.0

Corporate Headquarters: TEMCo – Tower Electric Motor Company 41474 Christy St. Fremont CA 94538 USA
Inside USA (800) 613-2290 International (510) 490-2187 Fax (510) 490-1507 www.temcoindustrialpower.com